

Regain the freedom of your outdoor space

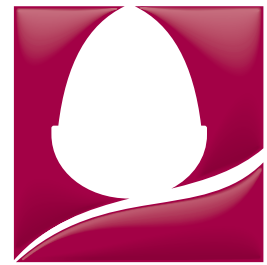

ACORN
STAIRLIFTS

The Acorn 130 Superglide Outdoor Stairlift

The Acorn Superglide Stairlift is one of the most technologically advanced stairlifts available, helping thousands of people worldwide to reclaim full access to their home or garden. It's the safe, comfortable and simple solution to difficulty with outdoor steps.

The outdoor stairlift has all the features of the indoor stairlift, but is designed and manufactured specifically for outdoor use.

In addition the outdoor stairlift comes with a durable waterproof cover for the ultimate in outdoor protection.

The Acorn Superglide Outdoor Stairlift is ideal for situations involving any steps that are exposed to the elements, including garden steps, balconies, porches, verandas and garage or basement steps.

All metallic components are either made from aluminium, and are oil annealed or zinc plated before powder coating. Plastic components are heat and UV resistant, protecting the stairlift from color fading and ambient heat damage.

You can rest safe in the knowledge that tens of thousands of homes worldwide have already enjoyed the Acorn experience.



Give your life a lift[®]

Enjoy the home you love



A wealth of features for your benefit



- 1 Padded seat and backrest.
- 2 Easy to use controls.
- 3 Secure safety belt.
- 4 Folding arms, footrest and seat allow easy access to the stairway.
- 5 Swivel seat - no need for twisting the body to get on and off the lift.
- 6 Lockable on/off switch allows the user to prevent others (e.g. children) from using the lift.
- 7 Diagnostic digital display informs the user of the status of the lift.
- 8 Five safety sensors on the footrest and carriage stop the lift automatically if any obstruction is encountered.
- 9 Hand-held remote controls allow users to 'call' or 'send' the lift up and down the staircase.

Dimensions

| | mm | inch |
|---|-----------|-----------|
| A Floor to top of footrest | 95 | 3¾ |
| B Top of footrest to top of seat | 445 | 17½ |
| C Top of seat to top of arms | 250 | 9¾ |
| D Top of arms to top of seat back | 190 | 7½ |
| E Width between armrests (Wide arm version) | 445 (495) | 17½ (19½) |
| F Overall width | 605 | 23¾ |
| G Overall height | 980 | 38½ |
| H Length of arms from seat back | 470 | 18½ |
| I Length of seat base from seat back | 435 | 17 |
| J Length of footrest | 325 | 12¾ |
| K Width of footrest | 310 | 12¼ |
| L Front of footrest to stringer | 570 | 22½ |
| M Back of seat to stringer | 13 | ½ |
| N Folded width | 310 | 12¼ |

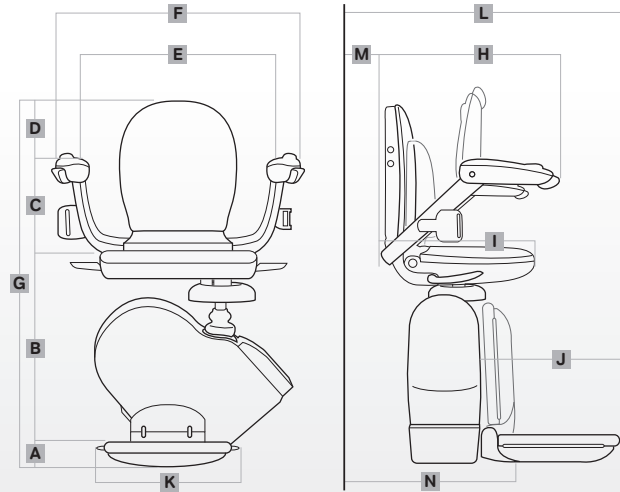

Specifications

| | | | |
|---------------------|--------------------------|------------------|----------------------------------|
| Motor Power | 0.25KW | Power Supply | 24V DC (battery) |
| Motor Output Speed | No greater than 0.15 m/s | Maximum Capacity | 127kgs |
| Method of Drive | Rack and Pinion | Track | Extruded Aluminium |
| Motor Output Torque | 108Nm | Mains Supply | UK 240V / EC 220V - 50Hz Charger |

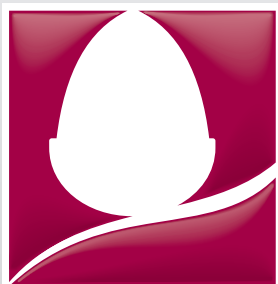

ACORN
STAIRLIFTS

Dealer Stamp

Acorn Mobility Services Ltd · Telecom House
Millennium Business Park · Station Road · Steeton · West Yorkshire · BD20 6RB

Acorn reserves the right to change specifications without notice. All measurements are approximate. Images are shown for illustrative purposes only. Product may vary slightly.